

## PRECAUTIONS

Read these precautions carefully before using your speaker.

- Any time you note distortion, reduce the volume control on your amplifier to a lower setting. Never allow your amplifier to be driven into "clipping". Otherwise the speaker may be damaged.
- When using an amplifier with a rated output power higher than the nominal input power of the speaker, care should be taken never to exceed the speaker's maximum input.
- Do not attempt to clean the speaker with chemical solvents as this might damage the finish. To clean, wipe with a dry, soft cloth.
- To prevent the enclosure from warping or discoloring, do not place the speaker where it will be exposed to direct sunlight or excessive humidity.
- Do not place the speaker where it is liable to be knocked over or struck by falling objects. Stable placement will also ensure better sound performance.
- Placing the speaker on the same shelf or rack as the turntable can result in feedback.
- This speaker system is designed for home use only. Never use this speaker system inside a car.
- **Secure placement or installation is the owner's responsibility.**  
**YAMAHA shall not be liable for any accident caused by improper placement or installation of the speaker.**

## ATTACHING STAND

Attach the included stands to the speakers using the two included screws. Place the speakers next to a personal computer on a desktop to achieve the optimum listening position. Be sure to attach the stands to the speakers correctly as shown in the figure. If you attach them in the opposite direction or otherwise incorrectly, the speakers may fall and be damaged or cause injury.

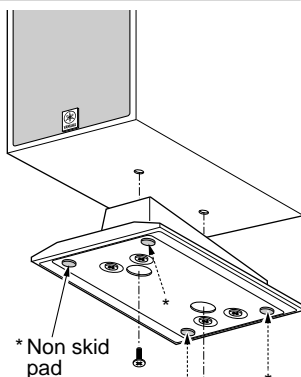

### ■ Non skid pad

To prevent the speakers from sliding around, attach the supplied pads as shown in the illustration.

You can also use the screw holes on the rear of the speaker for installing the speakers.

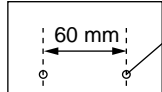

A screw with a diameter of 4 mm and a pitch of 0.7 mm can be used. (Depth of hole: 8 mm)

## CONNECTION TO YOUR AMPLIFIER

**BEFORE MAKING CONNECTIONS, MAKE SURE THAT THE AMPLIFIER IS SWITCHED OFF.**

### ■ CONNECTIONS

- Connect the push-type input terminals at the rear of the speakers to the speaker output terminals of your amplifier with the provided speaker cord.
- One side of the speaker cord is marked by a red line. Connect the (+) terminals on both the amplifier and the speakers using this red-marked side. Connect the (-) terminals on both components using the black-side of the cord.
- Connect one speaker to the left (marked L) terminals of your amplifier, and another speaker to the right (marked R) terminals, making sure not to reverse the polarity (+, -). If one speaker is connected with reversed polarity, the sound will be unnatural and lack bass.

Procedures:

- 1 Press the tab on the terminal down, as shown in the figure.
- 2 Insert the bare speaker wire end properly into the terminal hole. [Remove approx. 5 mm (1/4") insulation from the speaker cord.]
- 3 Remove your finger from the tab to allow it to lock snugly on the cord's wire end.
- 4 Test the security of the connection by tugging lightly on the cord at the terminal.

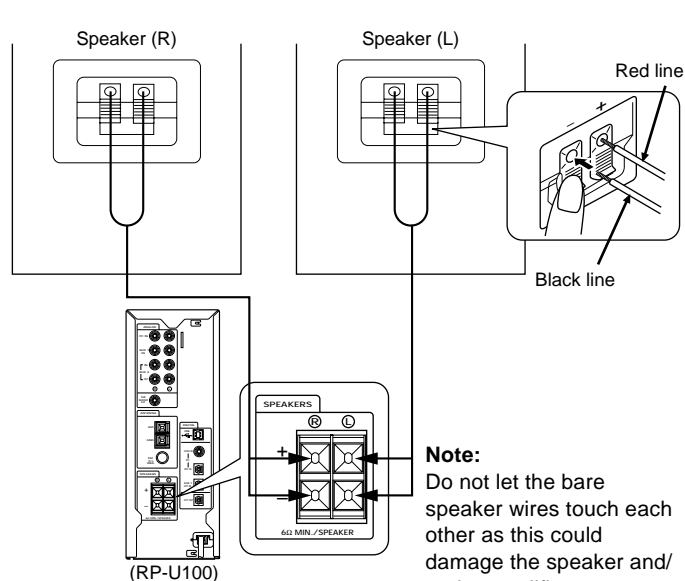

**Note:**  
Do not let the bare speaker wires touch each other as this could damage the speaker and/or the amplifier.

## SPECIFICATIONS

Type	: 2-way acoustic suspension magnetic shielding
Driver	: Woofer ..... 9 cm (3-1/2") cone Tweeter .... 2.5 cm (15/16") balanced dome
Nominal input power	: 40 W
Maximum input power	: 100 W
Frequency response	: 75 Hz – 30 kHz
Sensitivity	: 88 dB
Crossover frequency	: 5 kHz
Impedance	: 6Ω

Dimensions (W × H × D)	: 110 (4.3") × 293 (11.5") × 192 (7.6") mm (stand included)
Weight	: 2.0 kg (4.4 lbs) (stand included)
Accessories	: Stand × 2 Screws for stand × 4 Non skid pad × 8 Speaker cord × 2